



# ATTENTION:

This packet contains important information that must be read before starting engine!

Failing to do so could void your warranty!

**DO NOT ALLOW ENGINE TO IDLE**  
**UNTIL BREAK IN IS COMPLETE!**

*Thank you for your purchase.*

Please be sure to read the warranty information for details on coverage and exclusions to the warranty.

If you have any questions, please contact us at

**1-888-477-8006**

# Engine Installation Tips

## Before Installation:

- Determine the cause of engine failure: overheating, Ignition problems, fuel in oil, etc.
- Thoroughly clean any parts which will be reused, including bolts. Be sure no vacuum or EGR passages are restricted as this can cause oil consumption and smoking.
- Clean out any carbon build-up in throttle body areas.
- Check all gasket and seal mating surfaces for warping, gouges or other types of damage which could result in seal failures.
- Clean all gasket surfaces of oils, **paint**, etc.
- Use your torque wrench. Torque all bolts in sequence if you need specifications contact our shop. Lightly lube bolt threads. Use a quality Torque wrench.
- Before starting, prime the new oil pump with engine oil. See included oil pump priming document.
- Install new cooling system components, such as water pump, thermostat, hoses, etc.
- Install new air, fuel, and crankcase filter; as well as the PCV valve.
- Motor mounts, fuel pumps, charging system components, ignition components (including spark plugs and wires) should be replaced.

## After Installation:

- Monitor oil pressure gauge/light. Full oil pressure should be present immediately upon start up. Stop engine immediately if no oil pressure is observed.
  - Visually check for fluid leaks. If leaks are visible, stop engine immediately and repair before restarting.
  - Listen for any unusual noises. Knocking, tapping, scraping, etc. should not be heard. If so, stop engine immediately.
  - Monitor temperature gauge during warm up. use an external device to monitor temperature. Do NOT allow engine to overheat before completing cooling system fill procedure.
- OVERHEATING WILL VOID ENGINE WARRANTY.**
- **For flat-tappet cam/lifter break in, add one bottle of ZDDP-# Zinc oil additive. Run engine at 2,000 - 2,500 RPMs for the first 30 minutes of operation**, this can be done in 10-minute intervals allowing engine to cool back down in between sessions. **DO NOT ALLOW ENGINE TO IDLE DURING BREAK IN.**
  - Change oil and filter at 500 miles and every 3,000 miles/3 months thereafter.
  - Ask your professional engine rebuilder any questions you have about this checklist.

# Important Note regarding AMC/Jeep 360 – 304 V8 engines.

To validate any potential warranty claims a receipt indicating a NEW timing cover with oil pump assembly has been used with the long block purchased from Titan Engines is required.

The timing cover is available at many quality engine parts suppliers. Titan Engines recommend Engine Quest as a source for this part. Engine Quest pretests all of their oil pump timing cover combos to verify function before the sale and their quality is top notch.

This link will take you to their part listing for the Jeep/AMC 360-304 V8 Engine listings.

<https://enginequest.com/product/jeep-timing-cover-290-304-343-360-390-401-67-78-with-oil-pump-new/>

# INSTALLATION NOTES

- On vehicles that are equipped with an oil cooler, you must replace the oil cooler, or the warranty will be voided.
- The oil pump must be primed, and the oiling system purged of air before the engine is started or you will void the warranty.
- The radiator should be flushed or replaced. Do not forget to flush the heater core.
- Engines with adjustable rocker assemblies must be readjusted after engine "break in period".
- You must have the oil pan, valve cover(s), timing cover and intake manifold cleaned. Your warranty will be voided if dirt from these items enters the oil system.
- Intake manifold must be thoroughly cleaned. Sandblasting is not recommended.

## CORE RETURN

**Shipping charges incurred by Titan Engines for all core returns are deducted from the value of the returned core.** Contact Titan Engines to schedule your core return or arrange return shipping on your own. Cores returned by customers will not have shipping charged deducted. The core will be inspected and all damage that reduces its viability to be rebuilt will be deducted from the value of the returned core.

## WARRANTY INFORMATION

Please review the warranty documents. You can validate your warranty at <https://titanengines.com/warranty> click the "Register Now" button to begin the validation.

## CONTACT INFORMATION

Titan Engines	352-732-8006
	1-888-477-8006
2120 NW 10th St	<a href="http://www.titanengines.com">www.titanengines.com</a>
Ocala, FL 34475	<a href="mailto:info@titanengines.com">info@titanengines.com</a>

We are located on Highway 27 (NW 10th St) just two miles East of I-75 in Ocala, FL; exit number 354. Please check in at the front counter before taking core to drop-off area.



## OIL

Titan Engines recommends a 10w30 High zinc, High Phosphorus flat tappet engine oil for regular use with 3000 to 3500 mile oil change intervals.

### We recommend the following oils

#### For 30-minute break in period

We recommend a Straight 30 weight break in oil such as Amzoil break in oil, Lucas w30 Break in oil or Driven GP-1 Break-in 30 grade oil.

#### For the extended break in period (500 miles)

We recommend Valvoline VR-1 10w30 Racing oil or Driven GP-1 Break-in 30 grade oil.

#### For regular daily use

Driven GP-1 10w30 (partial Synthetic). Valvoline VR1 racing oil, Schaeffer's 10w30 Racing oil Micron Moly.

*[Titan Engines offers the recommended oils on our Online store.](#)*

Modern oil (2010 to present day) has seen significant changes in the levels of additives like Zinc, Phosphorus and other essential additives. These additives keep flat tappet camshafts and lifters running smoothly in your engine. The changes were meant to lengthen the life of emissions equipment such as catalytic converters and sensitive sensors in the exhaust system. However, these modern oils do not take into consideration that the engines NEED these additives to stay on the road for hundreds of thousands of miles. The flat tappet camshaft became a thing of the past and automotive manufacturers no longer manufacture flat tappet cam shaft engines.



# **REAR MAIN SEALS**

---

**ARE NOT COVERED BY  
WARRANTY WHEN NOT  
INCEDENTAL TO COVERED  
REPAIRS.**

Please see Titan Engines Limited Warranty,  
“Covered components” section, sub section three “seals & gaskets”.

# Important NOTE!

If your previous engine failed in a catastrophic fashion such as a blown-up piston, rod through the block or any other sudden catastrophic end, you **MUST** disassemble and inspect the parts to be reused. The Intake manifold, the Oil Pan, the Timing cover all must be inspected closely and cleaned to ensure no debris is left behind that will cause problems in the new engine. Foreign objects from the previous engine are not covered by the Titan engines Limited Warranty.

# Important NOTE!



## How to Prime the Oil Pump

Priming the oil pump in your Jeep engine brings the oil pressure up to normal before the engine is started. This will protect the engine from premature failure caused by a dry start. Dry start is a condition where the engine is initially run for a short time *without lubrication on the bearings*. This can wipe and spin bearings, causing quick and devastating damage to the engine internals. Priming the engine using the following instructions ensures that there is proper lubrication on all internal parts the first time the engine is started. Once the engine has been primed and run for the first time a thin layer of oil will always remain on all bearings and protect them for those first few critical seconds during startup while pressure builds.

**OIL PUMP PRIMING IS THE MOST IMPORTANT STEP TO TAKE JUST BEFORE STARTING YOUR ENGINE FOR THE FIRST TIME!**

**DO NOT PRIME THE PUMP WITH THE STARTER, FOLLOW THE INSTRUCTIONS BELOW!**

1. After you install the engine into the Jeep's engine compartment ensure that you install a new name-brand oil filter such as Wix and fill the engine with the proper amount of oil. Using the factory oil pan and oil dipstick fill to the factory level on the stick.
2. Install the priming tool into the engine through the distributor hole and attach an electric drill to the priming tool. If you don't have a priming tool, you may cut the handle off a flathead screwdriver and use that to turn the oil pump drive shaft.
3. Turn the drill clockwise until you feel the drill load-up. This may take a few minutes, but you will eventually feel the drill start to torque back on your arm. This is a sign that the oil has now been pulled through the oil pump pick-up tube and is now pumping through the engine.
4. Continue running the drill for another minute after the drill loads-up. This ensures that all the bearings and moving components have been properly lubricated.
5. After priming is completed be sure to you have installed the distributor correctly and start the engine.

**If you have any questions regarding priming the oil pump, please contact us at**

**1-888-477-8006**



## Installing the Jeep Distributor/Cam Sensor

1. Ensure the #1 piston is at Top Dead Center on the compression stroke. To find TDC on the compression stroke you can remove the #1 spark plug and put your finger over the spark plug hold while you have someone turn the engine over slowly by hand. Once you feel pressure building up on your finger bring the piston to the TDC and you've got it.
2. Remove the distributor cap and rotor and look at the pulse ring on the distributor (see picture below). **NOTE THAT THERE ARE TWO HOLES:** one for the 2.5 (4) cylinder engine and one for the 4.0 (6) cylinder engine (the pulse ring is located under the rotor and may require you to remove the plastic dust cover to expose it).
3. Insert a 3/16" pin (an Allen Wrench will do) into the small hole under the bottom side of the distributor base. Then find the 4.0 (6) cylinder hole in the pulse ring which is located at the end of the half-moon pulse ring and line the two up and lock out the pulse ring. Note: The hole that is "free" is to time the four-cylinder engine, do not use for the six-cylinder engine.
4. Pre-position the oil pump slot at 11 o'clock to accept the distributor drive as shown in the picture below.
5. Insert the distributor, engaging the oil pump. Note: The rotor will not be aligned to the #1 plug wire on the cap. Once the distributor is fully engaged and flush with the block remove the alignment pin.
6. Install and tighten the securing bolt at the base of the distributor. Do not rotate the distributor base at all as this will not change the ignition timing since this is a cam sensor for the engine.

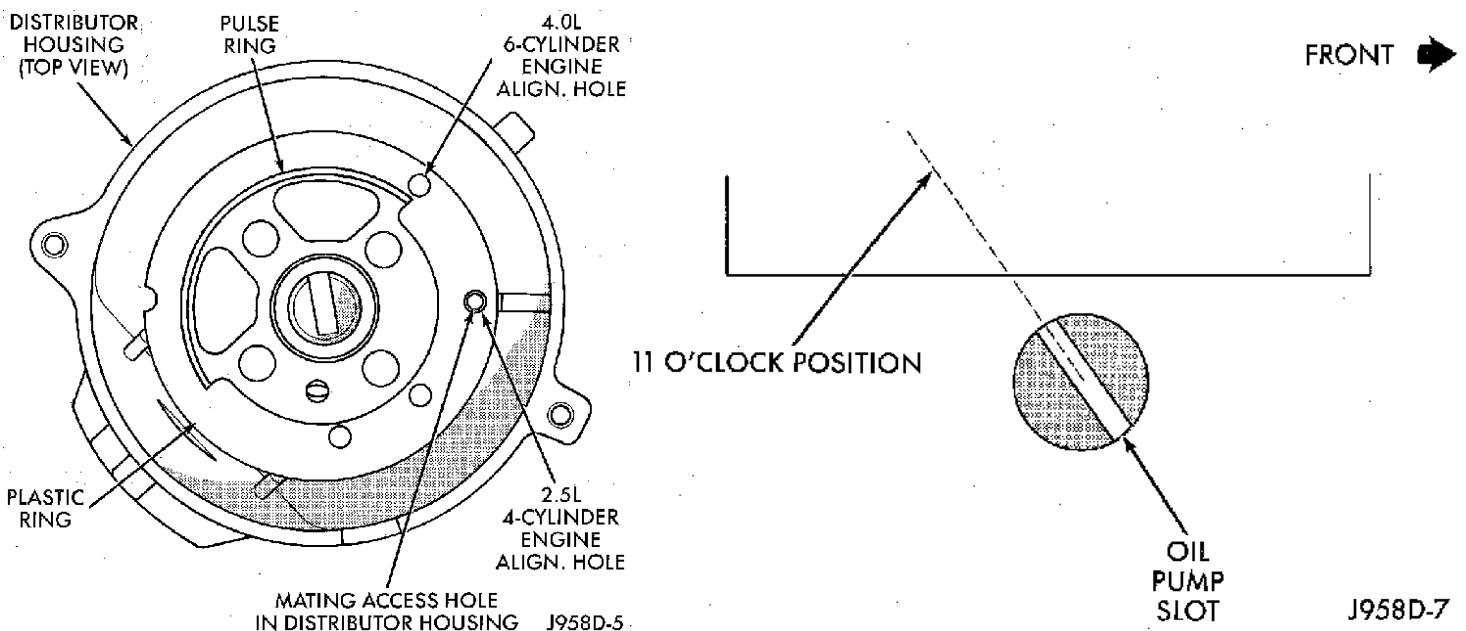

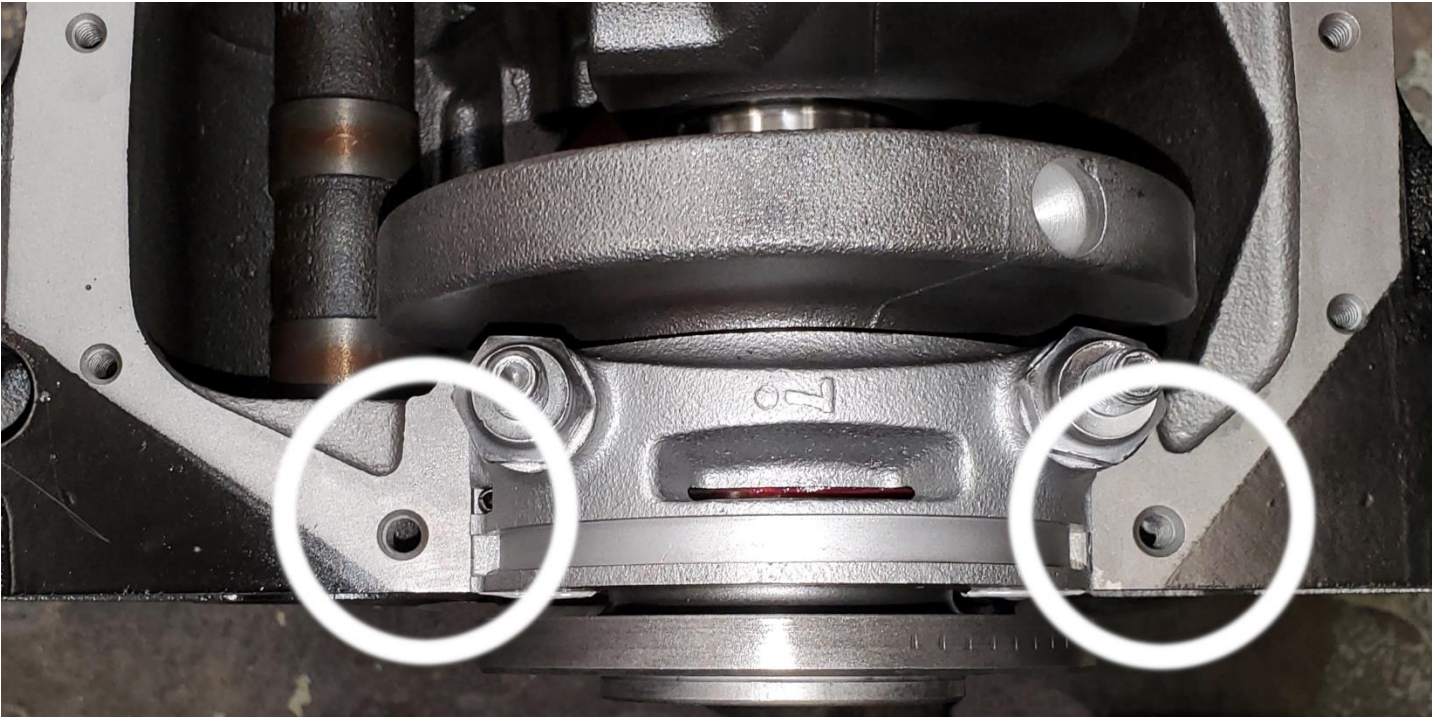

## 242 CID 4.0 Liter Jeep Engine

### '01 And Up Oil Pan Gasket Installation Caution

The OE Made a change in the construction of the oil pan gasket rear end beginning in 2001. The difference between the 2 gaskets affects the fitment and proper installation. The gasket set **with** extended tabs fits '01 and newer engines. The gasket **without** extended tabs fits '00 and older engines.

When installing an oil pan gasket without the extended tabs on the '01 and newer engines use silicon to fill the void areas circled on the above picture.

If you have any questions regarding priming the oil pump, please contact us at

**1-888-477-8006**

The following specifications are to help you install the engine and ensure proper torque on bolts. These images are presented for reference, if you have questions please contact our office at 352-732-8006 The engine specifications are for both Wrangler and Cherokee models and apply to either.

Torque specifications.

Jeep 4.0

<b>Overview</b>						
<b>Created:</b> Aug 05, 1997		<b>Edited:</b> Apr 01, 2021				
<b>VEHICLE TYPE</b> Car/Truck	<b>FUEL TYPE</b> Gas	<b>CAMSHAFT</b>	<b>VALVE ADJ.</b> HYD	<b>ENGINE CODE</b> AMC/JEEP		
<b>MAKE</b> JEEP	<b>MODEL</b> WRANGLER	<b>YEAR</b> 1998-2006	<b>VIN</b> S	<b>LITER</b> 4.0	<b>CID</b> 242	<b>CYL</b> L 6
<b>BORE</b> 3.8759-3.8775" (98.448-98.489 MM)		<b>STROKE</b> 3.425" (86.995 MM)				
<b>COMPRESSION RATIO</b> 8.8:1 RATIO, CRANKING 120-150 PSI				<b>FIRING ORDER</b> 1-5-3-6-2-4		
<b>COMMENT</b> AMC/JEEP CHEROKEE, WRANGLER					<b>INTFR</b> Yes	
<b>Torque/Tune-Up</b>						
<b>Torque Specifications</b>						
Description	Specifications					
Intake Manifold	1-5 & 8-11 24FT/LBS, 6 & 7 10 FT/LBS					
Exhaust Manifold	1-5 & 8-11 24FT/LBS, 6 & 7 10 FT/LBS					
Flywheel	105 FT/LBS, HOUSING 28 FT/LBS					
Flywheel Bolt Sealer						
Flywheel Surfacing	FLAT - NEW THICKNESS = 1.192"					
Damper	80 FT/LBS					
Damper Bolt Sealer						
Main Bearing Cap	40,70,80 FT/LBS MAIN CAP BRACE 35 FT/LBS					
Additional Main Cap Bolts						
Connecting Rod	33 FT/LBS					
Cylinder Head	22, 45, 110 FT/LBS, EXCEPT BOLT #11=100 FT/LBS					
Camshaft Cap Torque						
Camshaft Gear Bolt	50 FT/LBS					
Comments						
<b>Additional Torque Specifications</b>						
ROCKER ARM BOLT	21 FT/LBS					
OIL PAN BOLTS	1/4" = 84 IN/LBS, 5/16" = 132 IN/LBS					
OIL PUMP BOLTS	204 IN/LBS, COVER = 70 IN/LBS					
WATER PUMP	17 FT/LBS					
FUEL RAIL	106 IN/LBS					
TORQUE CONVERTOR	28 FT/LBS					

Torque specifications.

Jeep 4.2

Overview		Created: Dec 07, 1992		Edited: Dec 28, 2021	
VEHICLE TYPE	Car/Truck	FUEL TYPE	Gas	CAMSHAFT	OHV
		VALVE ADJ.	HYD	ENGINE CODE	AMC/JEEP
MAKE	JEEP	MODEL	CJ-5	YEAR	1979-1989
		VIN	C	LITER	4.2
BORE	3.7500" (95.250 MM)	STROKE	3.895" (98.933 MM)	CID	258
COMPRESSION RATIO	150 PSI, 9.2:1	FIRING ORDER	1-5-3-6-2-4	CYL	L 6
COMMENT	AMC/JEEP EAGLE	INTFR	Unkown		
Torque/Tune-Up					
Torque Specifications					
Description	Specifications				
Intake Manifold	23 FT/LBS				
Exhaust Manifold	23 FT/LBS				
Flywheel	105 FT/LBS				
Flywheel Bolt Sealer					
Flywheel Surfacing	FLAT				
Damper	80 FT/LBS				
Damper Bolt Sealer					
Main Bearing Cap	75-85 FT/LBS				
Additional Main Cap Bolts					
Connecting Rod	30-35 FT/LBS				
Cylinder Head	* SEE TB 748				
Camshaft Cap Torque					
Camshaft Gear Bolt	80 FT/LBS				
Comments					
Additional Torque Specifications					
ROCKER ARM	19 FT/LBS				
CARB MOUNT BOLT	14 FT/LBS				
OIL PUMP MOUNT	SHORT 10 FT/LBS, LONG 17 FT/LBS				

Torque specifications.

Jeep 2.5

<b>Overview</b>		Created: May 28, 1992		Edited: Apr 01, 2021	
<b>VEHICLE TYPE</b> Car/Truck	<b>FUEL TYPE</b> Gas	<b>CAMSHAFT</b>	<b>VALVE ADJ.</b> HYD	<b>ENGINE CODE</b> AMC/JEEP	
<b>MAKE</b> JEEP	<b>MODEL</b> TRUCK	<b>YEAR</b> 1989-1993	<b>VIN</b> E	<b>LITER</b> 2.5	<b>CID</b> 150 <b>CYL</b> L 4
<b>BORE</b> 3.8751-3.8775" (98.428-98.489 MM)	<b>STROKE</b> 3.188" (80.975 MM)				
<b>COMPRESSION RATIO</b> 9.1:1 RATIO *				<b>FIRING ORDER</b> 1-3-4-2	
<b>COMMENT</b> AMC ENGINE 2.46 L JEEP					<b>INTFR</b> Unkown
<b>Torque/Tune-Up</b>					
<b>Torque Specifications</b>					
Description	Specifications				
Intake Manifold	23 FT/LBS				
Exhaust Manifold	23 FT/LBS				
Flywheel	50 FT/LBS, + 60°				
Flywheel Bolt Sealer	YES				
Flywheel Surfacing	FLAT				
Damper	80 FT/LBS				
Damper Bolt Sealer					
Main Bearing Cap	80 FT/LBS				
Additional Main Cap Bolts					
Connecting Rod	33 FT/LBS				
Cylinder Head	110 FT/LBS, #7 BOLT=100 FT/LBS, CAM BOLTS 27 FT/LBS				
Camshaft Cap Torque					
Camshaft Gear Bolt	50 FT/LBS SPROCKET				
Comments	* CRANKING COMPRESSION 120-150 PSI				
<b>Additional Torque Specifications</b>					
ROCKER ARM BOLT	21 FT/LBS				

# Important note regarding JEEP 4.7 Stokers.



## DO NOT RE-INSTALL THE STOCK MAIN BEARING GIRDLE.

If you have a new Stroker engine, the larger stroke will cause the rods to hit the girdle when rotating, causing an awful knocking sound, and potentially harming the engine with metal shavings from the girdle being struck.

(You can shim it if you know how to)

**The Following information is for later Jeep TJ's with the dome top Cam Position Sensor/Oil pump Drive.**

**Fig. 10 CMP ADJUSTMENT - 2.4L**

- 1 - FACE OF SENSOR
- 2 - WIRE GAPPING TOOL

## CAMSHAFT POSITION SENSOR - 4.0L

### DESCRIPTION - 4.0L

The CMP (Camshaft Position Sensor) sensor (2) (Fig. 11) is bolted to the side of the oil pump drive assembly (5). The assembly is located on the right side of the engine near the oil filter (Fig. 11).

### OPERATION - 4.0L

The CMP sensor (1) (Fig. 12) uses a rotating hall effect device called a target wheel (3) which is attached to the oil pump drive shaft. The target wheel contains sets of machined notches (2).

When the leading edge of a target wheel notch passes by the tip of the CMP sensor, the interruption of magnetic field causes the voltage to switch high resulting in a sync signal of approximately 5 volts.

When the trailing edge of the target wheel notch passes by the tip of the CMP sensor, the change of the magnetic field causes the sync signal voltage to switch low to 0 volts.

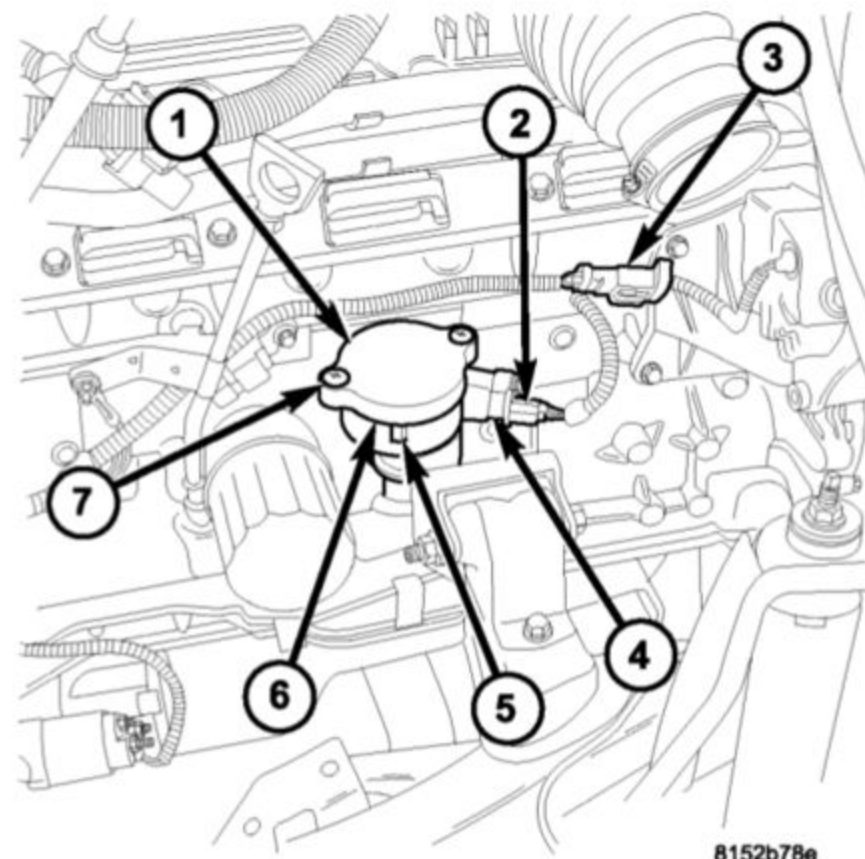

8152b78e

**Fig. 11 4.0L CMP LOCATION ('05)**

- 1 - OIL PUMP DRIVE ASSEMBLY
- 2 - CMP
- 3 - CMP ELECTRICAL CONNECTOR
- 4 - HOUSING HOLD DOWN BOLT
- 5 - HOUSING
- 6 - PLASTIC COVER
- 7 - COVER SCREWS (2)

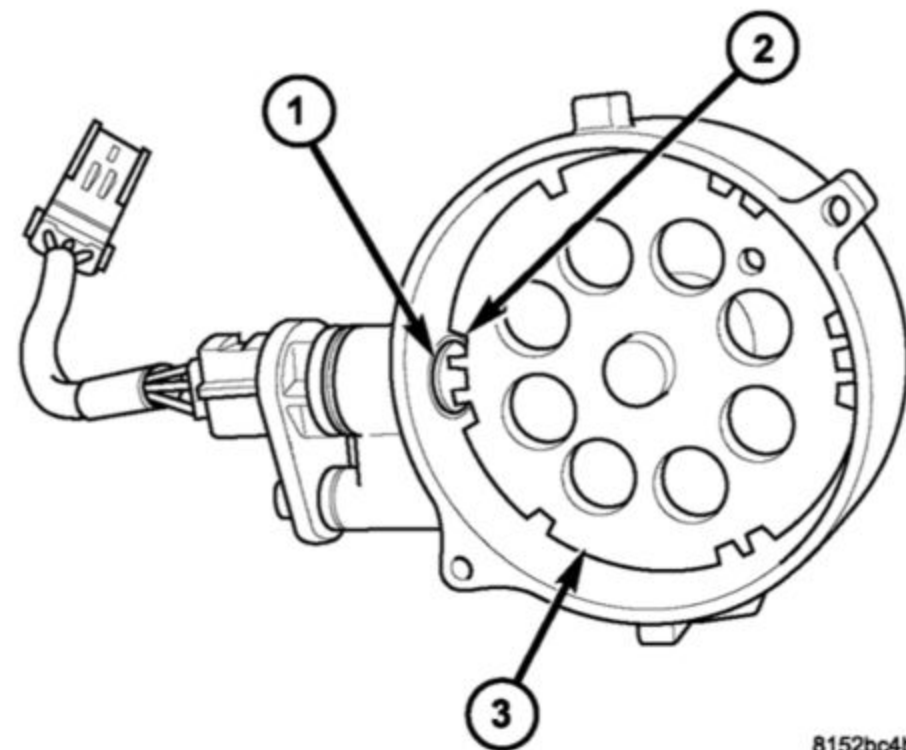

8152bc4b

**Fig. 12 4.0L CMP OPERATION**

- 1 - CMP SENSOR
- 2 - TARGET WHEEL NOTCHES
- 3 - TARGET WHEEL

**CAMSHAFT POSITION SENSOR - 4.0L (Continued)**

**REMOVAL - 4.0L**

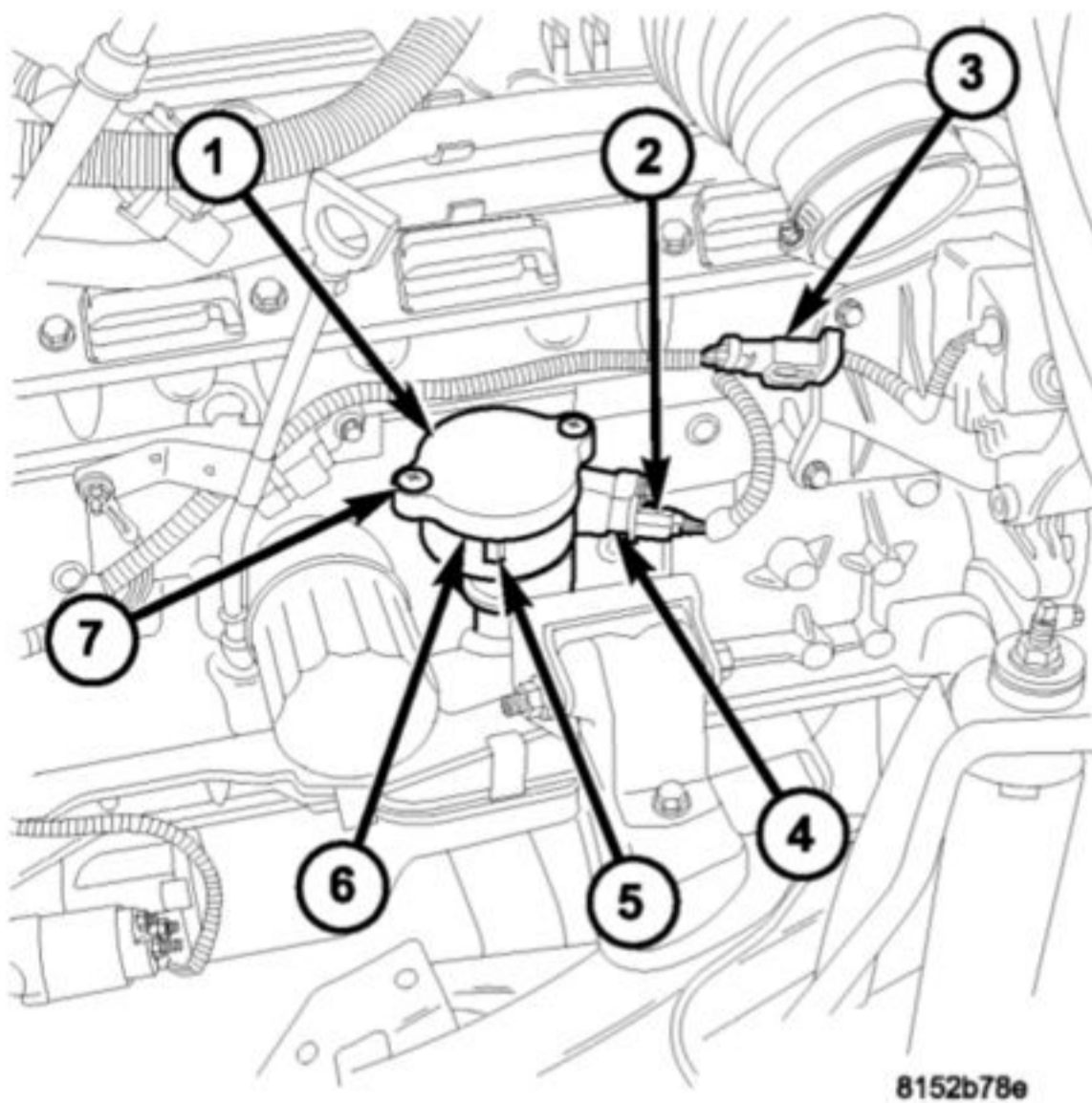

**Fig. 13 4.0L CMP LOCATION ('05)**

- 1 - OIL PUMP DRIVE ASSEMBLY
- 2 - CMP
- 3 - CMP ELECTRICAL CONNECTOR
- 4 - HOUSING HOLD DOWN BOLT
- 5 - HOUSING
- 6 - PLASTIC COVER
- 7 - COVER SCREWS (2)

The Camshaft Position Sensor (CMP) on the 4.0L 6-cylinder engine (2) is bolted to the side of the oil pump drive shaft housing assembly (5) (Fig. 13).

**NOTE: Do not attempt to rotate the oil pump drive assembly to modify ignition timing.**

Two different procedures are used for removal and installation. The first procedure will detail removal and installation of the sensor only. The second procedure will detail removal and installation of the sensor and oil pump drive shaft assembly. The second procedure is to be used if the engine has been disassembled.

**CMP SENSOR ONLY - 4.0L**

- (1) Disconnect CMP electrical jumper harness (3) at engine wiring harness (Fig. 14).
- (2) Remove sensor mounting bolt (3) (Fig. 15).
- (3) Remove sensor (2) from oil pump drive housing (1) (Fig. 15).

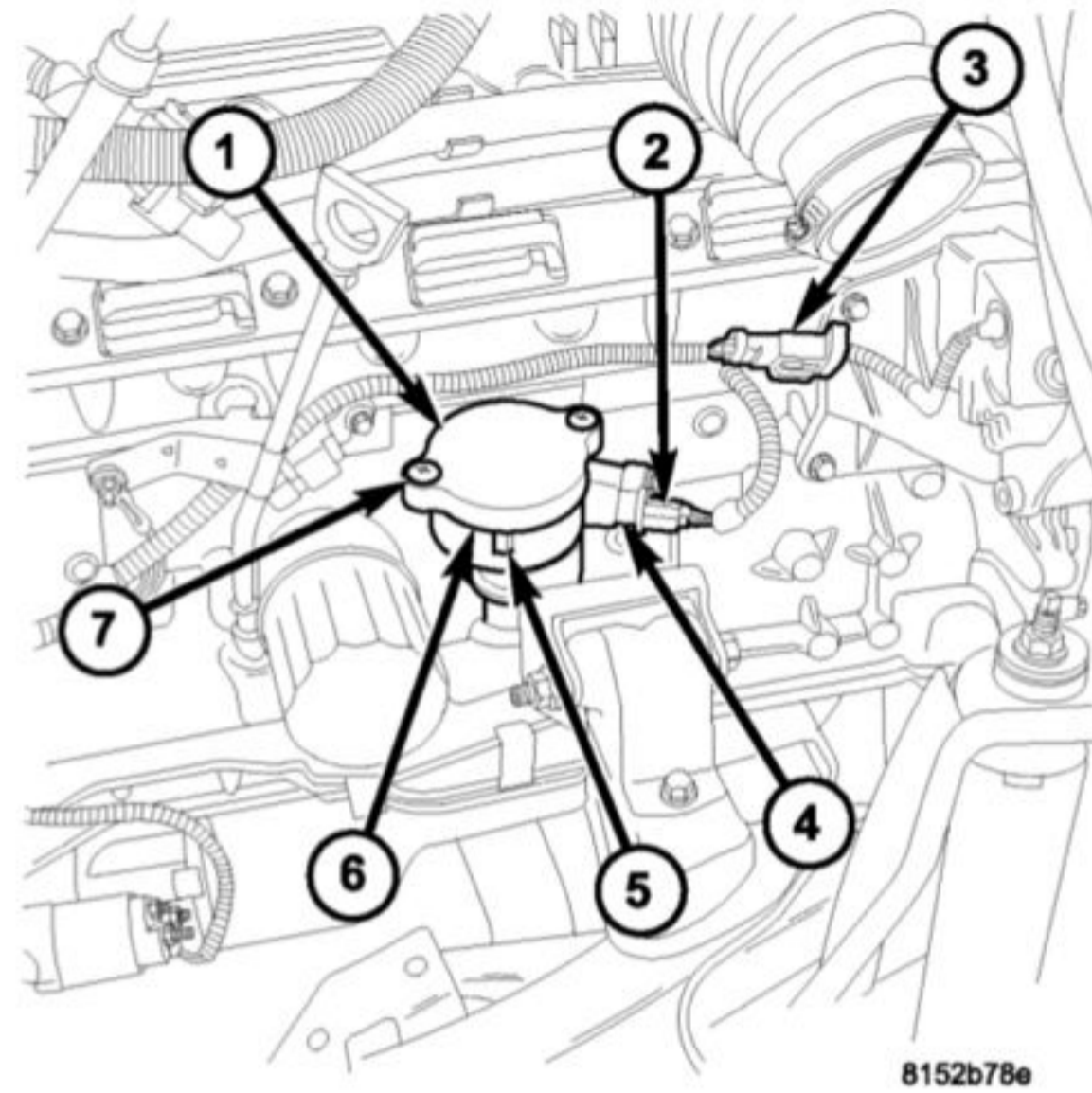

**Fig. 14 4.0L CMP LOCATION ('05)**

- 1 - OIL PUMP DRIVE ASSEMBLY
- 2 - CMP
- 3 - CMP ELECTRICAL CONNECTOR
- 4 - HOUSING HOLD DOWN BOLT
- 5 - HOUSING
- 6 - PLASTIC COVER
- 7 - COVER SCREWS (2)

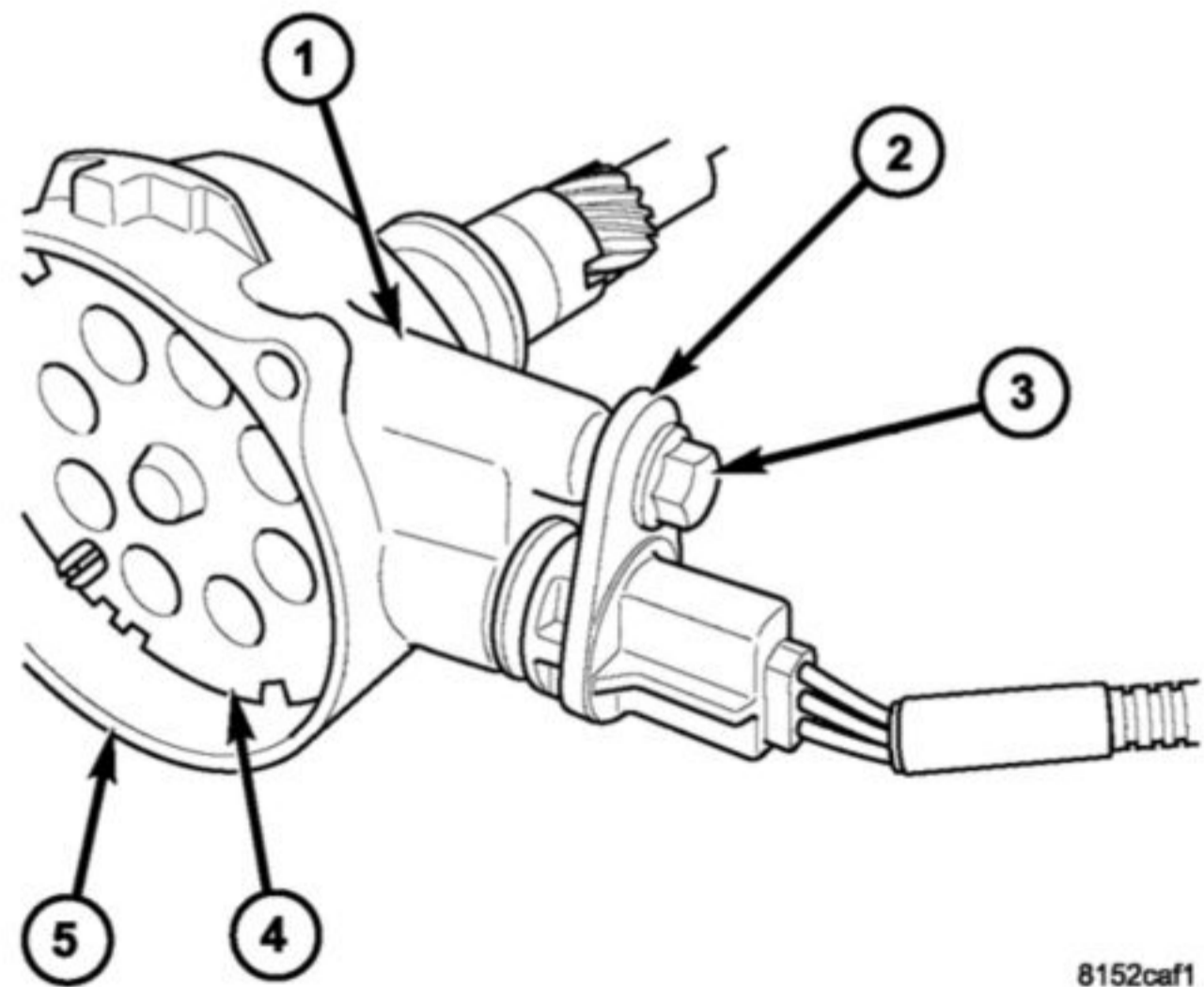
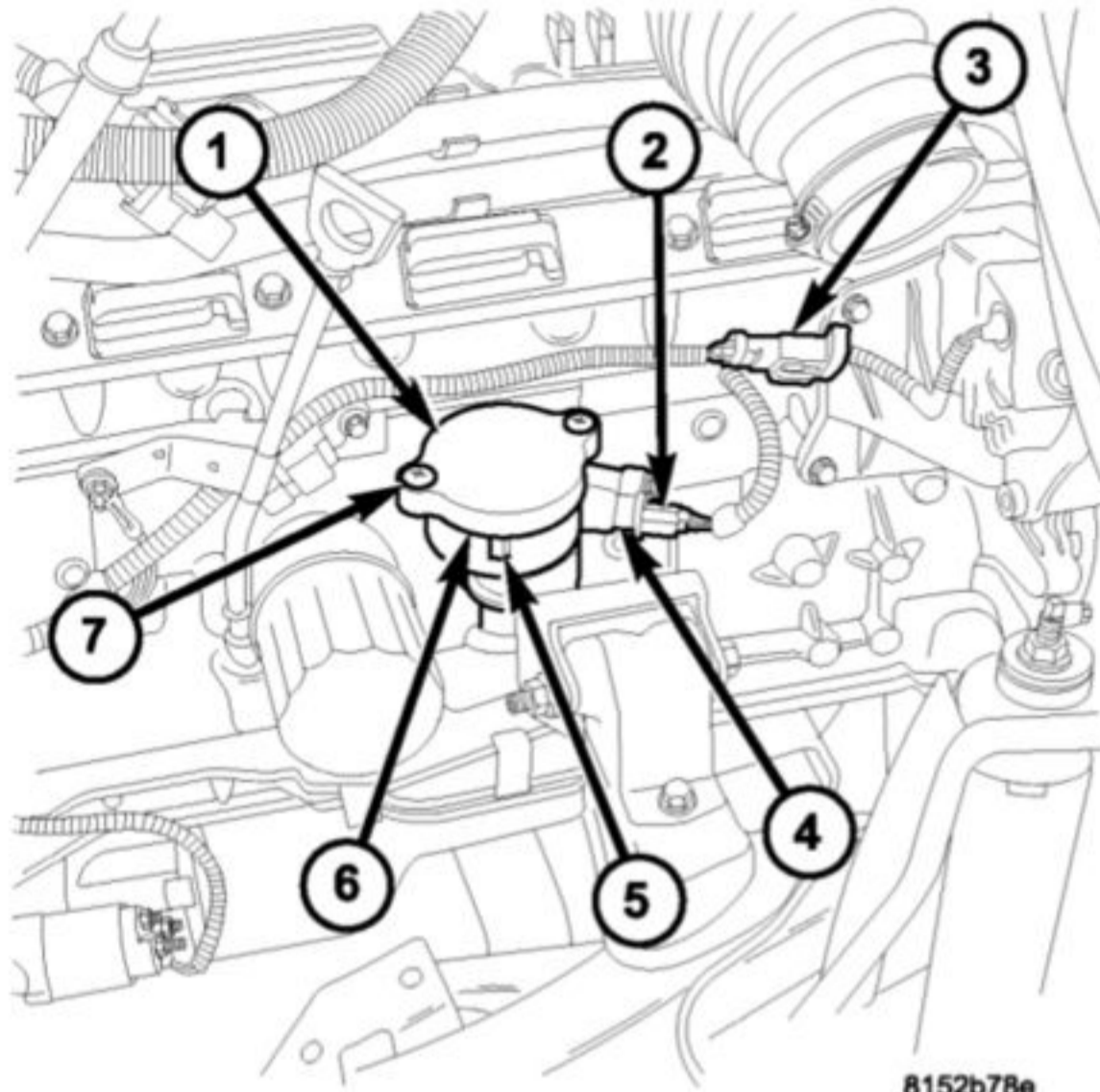

**Fig. 15 4.0L CMP REMOVAL/INSTALLATION**

- 1 - OIL PUMP DRIVE HOUSING
- 2 - CMP SENSOR
- 3 - SENSOR MOUNTING BOLT
- 4 - TARGET WHEEL
- 5 - HOUSING

**CAMSHAFT POSITION SENSOR - 4.0L (Continued)****OIL PUMP DRIVE AND CMP SENSOR - 4.0L**

If the CMP and oil pump drive are to be removed and installed, do not allow engine crankshaft or camshaft to rotate. CMP sensor relationship will be lost.



8152b78e

**Fig. 16 4.0L CMP LOCATION ('05)**

- 1 - OIL PUMP DRIVE ASSEMBLY
- 2 - CMP
- 3 - CMP ELECTRICAL CONNECTOR
- 4 - HOUSING HOLD DOWN BOLT
- 5 - HOUSING
- 6 - PLASTIC COVER
- 7 - COVER SCREWS (2)

(1) Remove two plastic cover screws (7) (Fig. 16) and remove plastic cover (6).

(2) Note and mark rotational position of target wheel (4) (Fig. 17) in relationship to housing (5).

(3) Disconnect CMP electrical jumper harness (3) at engine wiring harness (Fig. 16).

(4) Before proceeding to next step, mark and note rotational position of oil pump drive housing (5) (Fig. 16) in relationship to engine block. After installation, the CMP sensor should face the 4 o'clock position as viewed from right side of engine.

(5) Remove hold-down bolt (4) and clamp (Fig. 16).

(6) Pull assembly from engine.

(7) Remove and discard old oil pump drive-to-engine block gasket.

**INSTALLATION - 4.0L****SENSOR ONLY - 4.0L**

(1) Install sensor (2) (Fig. 18) to oil pump drive housing (1).

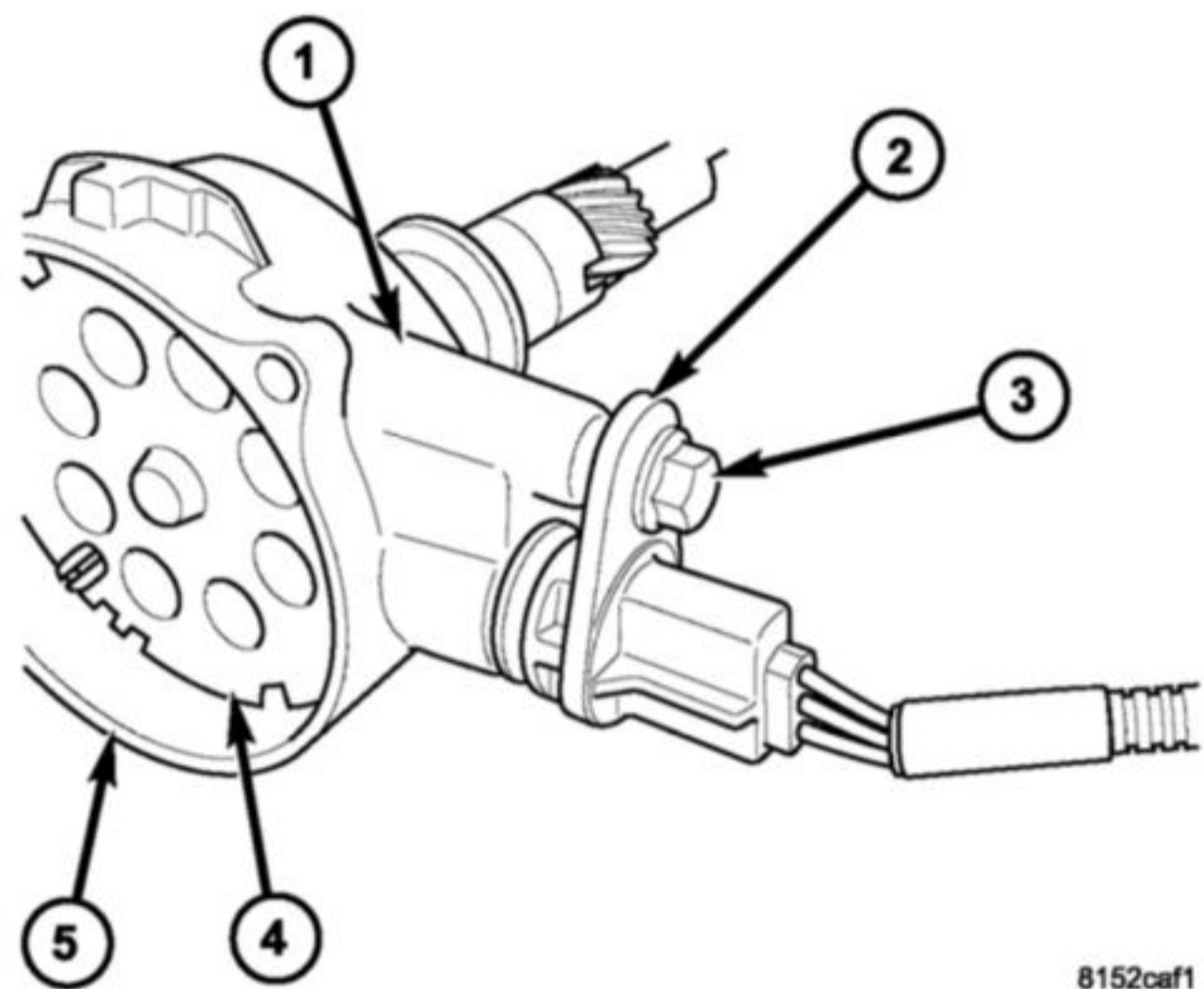

8152caf1

**Fig. 17 4.0L CMP REMOVAL/INSTALLATION**

- 1 - OIL PUMP DRIVE HOUSING
- 2 - CMP SENSOR
- 3 - SENSOR MOUNTING BOLT
- 4 - TARGET WHEEL
- 5 - HOUSING

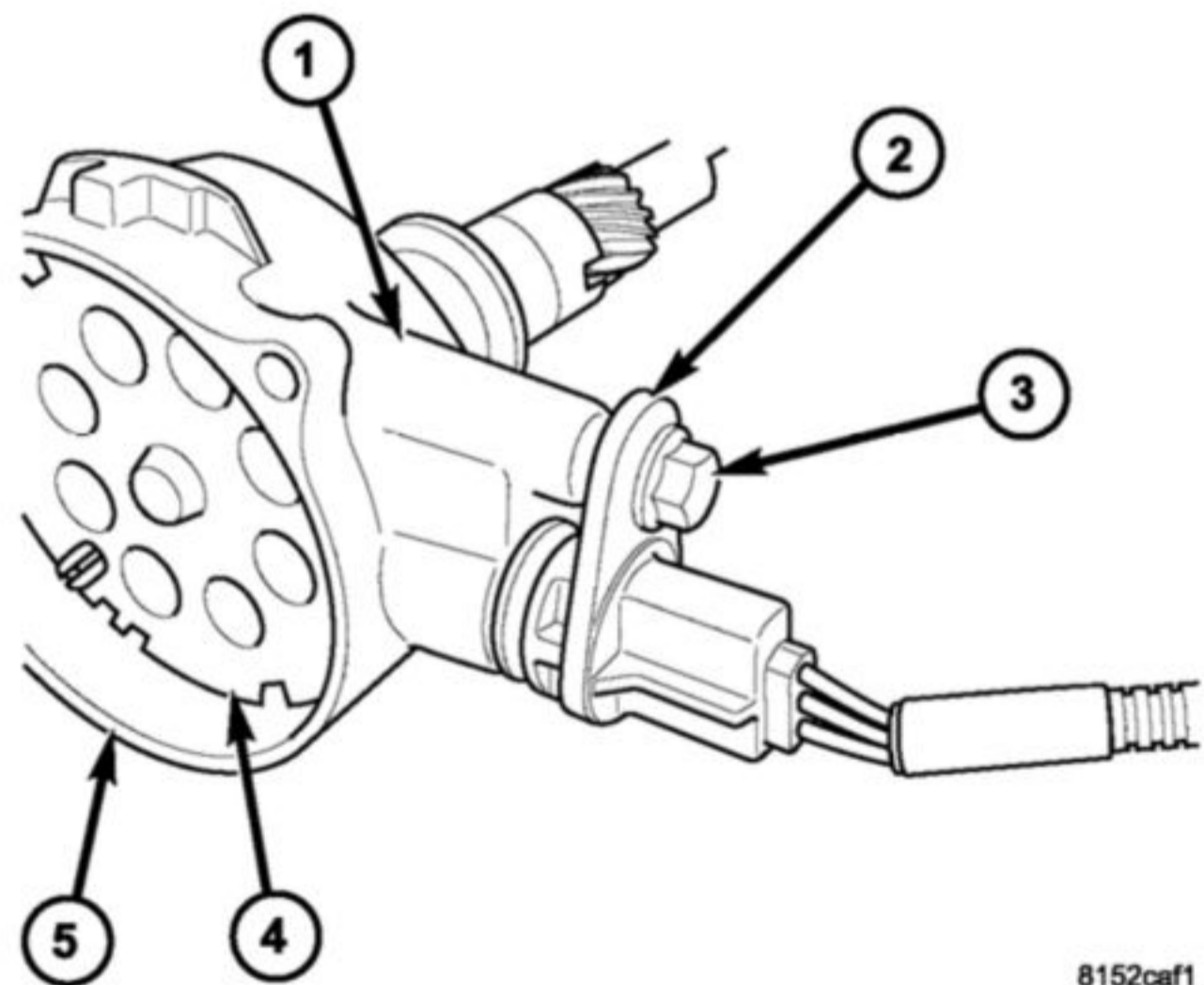

8152caf1

**Fig. 18 4.0L CMP REMOVAL/INSTALLATION**

- 1 - OIL PUMP DRIVE HOUSING
- 2 - CMP SENSOR
- 3 - SENSOR MOUNTING BOLT
- 4 - TARGET WHEEL
- 5 - HOUSING

(2) Install sensor mounting bolt (3) (Fig. 18) and tighten to 2 N·m (15 in. lbs.) torque.

(3) Connect CMP electrical jumper harness (3) (Fig. 19) to engine wiring harness.

## CAMSHAFT POSITION SENSOR - 4.0L (Continued)

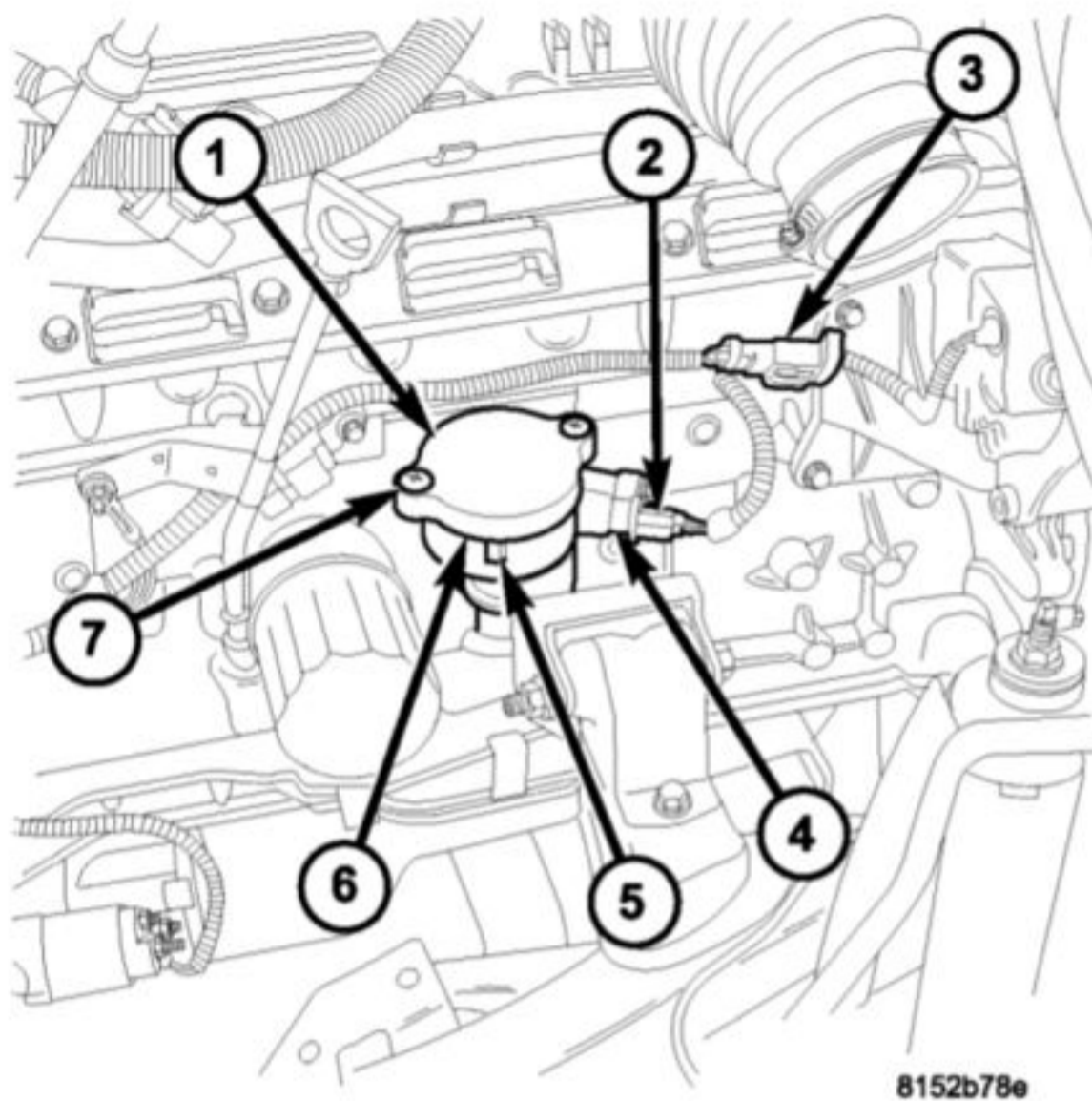

8152b78e

Fig. 19 4.0L CMP LOCATION ('05)

- 1 - OIL PUMP DRIVE ASSEMBLY
- 2 - CMP
- 3 - CMP ELECTRICAL CONNECTOR
- 4 - HOUSING HOLD DOWN BOLT
- 5 - HOUSING
- 6 - PLASTIC COVER
- 7 - COVER SCREWS (2)

## OIL PUMP DRIVE AND CMP SENSOR - 4.0L

(1) Clean oil pump drive mounting hole area of engine block.

(2) Install new oil pump drive-to-engine block gasket.

(3) If installing a new oil pump drive assembly, it is supplied with a temporary alignment pin (2) (Fig. 20) to prevent the target wheel from rotating. Do not remove this pin until oil pump drive assembly (1) has been installed.

(4) If installing/returning a used oil pump drive assembly back to the engine, temporarily install a small screwdriver (1) (Fig. 21) or similar tool through target wheel access hole (2) and then through mating hole in housing (3).

(5) Install oil pump drive into engine while aligning into slot on oil pump. Rotate oil pump drive housing back to its original 4 o'clock position as viewed from right side of engine. Install hold-down clamp and bolt. Tighten bolt.

(6) If engine crankshaft or camshaft has been rotated, such as during engine tear-down, CMP sensor relationship must be reestablished.

(a) Remove ignition coil rail assembly. Refer to Ignition Coil Removal/Installation.

(b) Remove cylinder number 1 spark plug.

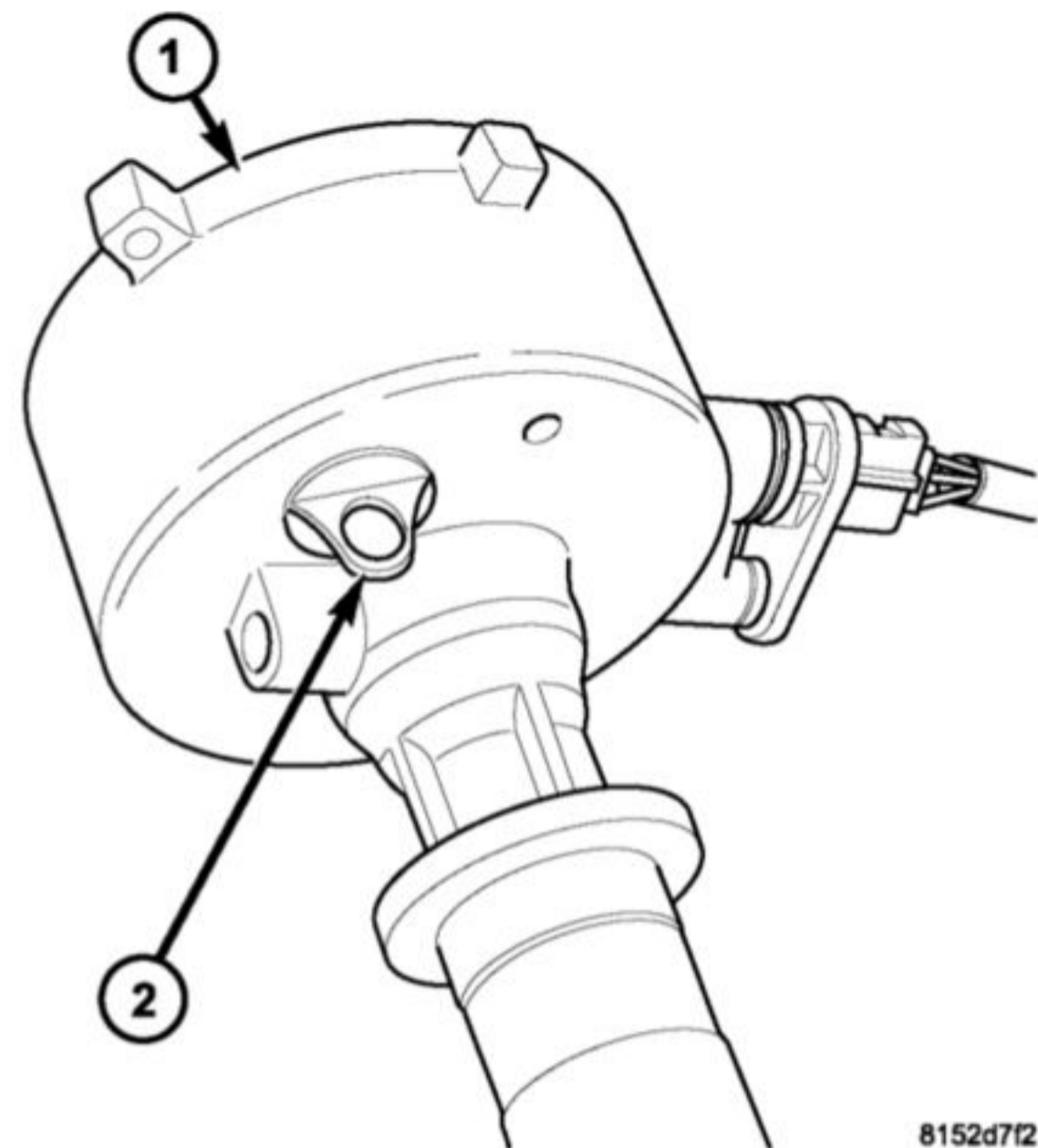

8152d7f2

Fig. 20 4.0L CMP FACTORY ALIGNMENT PIN

- 1 - OIL PUMP DRIVE HOUSING
- 2 - FACTORY ALIGNMENT PIN

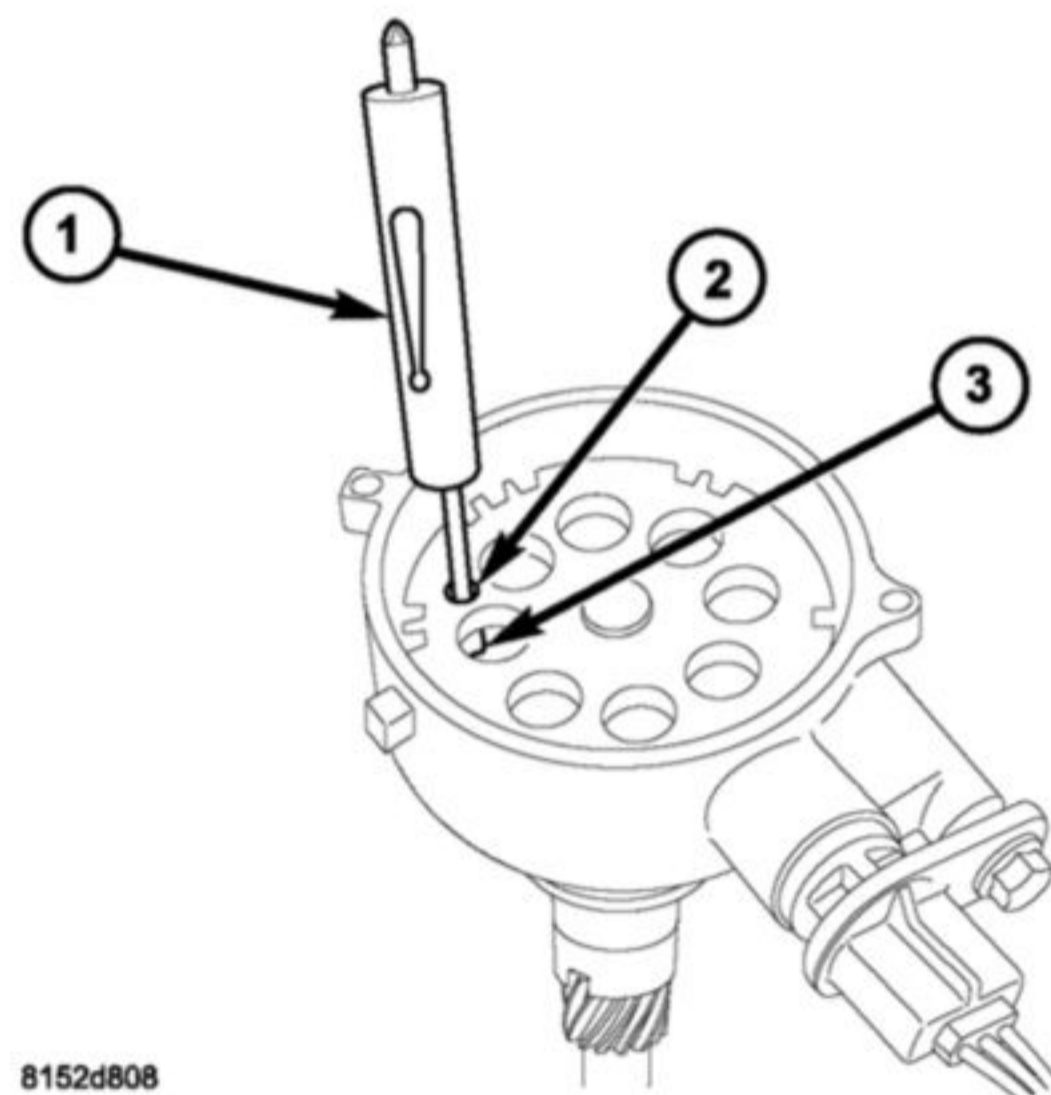

8152d808

Fig. 21 4.0L CMP TARGET WHEEL ALIGNMENT

- 1 - SMALL SCREWDRIVER
- 2 - TARGET WHEEL ALIGNMENT HOLE
- 3 - HOUSING ALIGNMENT HOLE

(c) Hold a finger over the open spark plug hole. Rotate engine at vibration dampener bolt until compression (pressure) is felt.

(d) Slowly continue to rotate engine. Do this until timing index mark (1) (Fig. 22) on vibration damper pulley aligns with top dead center (TDC) mark (0 degree) on timing degree scale. Always

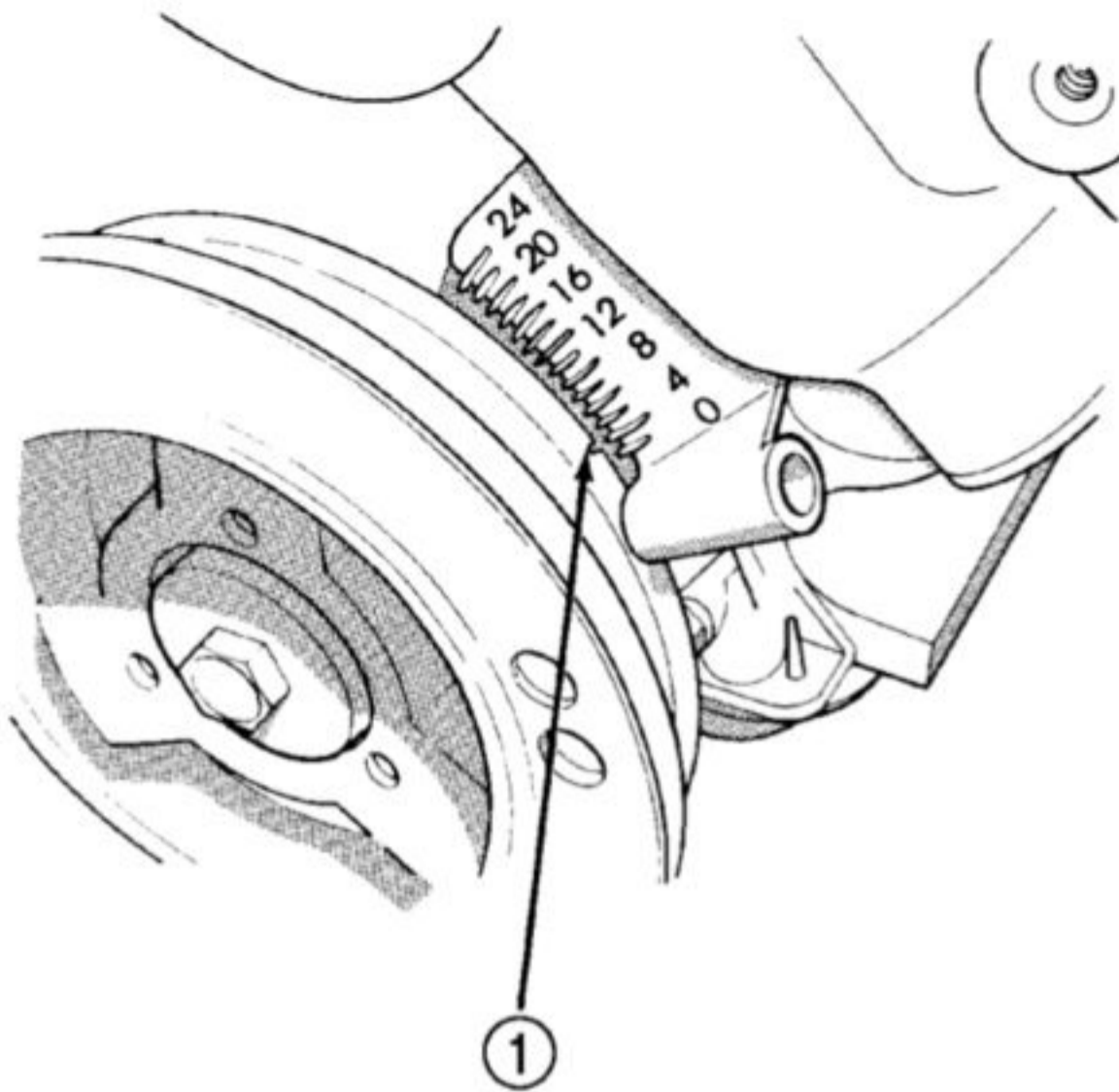
**CAMSHAFT POSITION SENSOR - 4.0L (Continued)**

J898D-14

**Fig. 22 Align Timing Marks - 4.0L Engine**

1 - CRANKSHAFT VIBRATION DAMPER TIMING MARK

rotate engine in direction of normal rotation. Do not rotate engine backward to align timing marks.

(e) Install oil pump drive into engine while aligning into slot on oil pump. If pump drive will not drop down flush to engine block, the oil pump slot is not aligned. Remove oil pump drive and align slot in oil pump to shaft at bottom of drive. Install into engine. Rotate oil pump drive housing back to its original 4 o'clock position as viewed from right side of engine. Install hold-down clamp and bolt.

(f) Remove small screwdriver, or, factory alignment pin from housing and install plastic cover (two screws).

(7) Install CMP sensor to oil pump drive.

(8) Install sensor mounting bolt and tighten to 2 N·m (15 in. lbs.) torque.

(9) Connect CMP electrical connector to engine wiring harness.

(10) If removed, install spark plug and ignition coil rail.

(11) Connect DRB scan tool to data link connector. The data link connector is located in passenger compartment, below steering column.

(12) Gain access to "CAM/CRANK RELEARN" screen on DRB scan tool.

**COIL RAIL - 4.0L****DESCRIPTION - 4.0L**

A one-piece coil rail assembly containing three individual coils is used on the 4.0L 6-cylinder engine (Fig. 23). The coil rail must be replaced as one assembly. The bottom of the coil is equipped with 6 individual rubber boots (Fig. 23) to seal the 6 spark plugs to the coil. Inside each rubber boot is a spring. The spring is used for a mechanical contact between the coil and the top of the spark plug. These rubber boots and springs are a permanent part of the coil and are not serviced separately.

(1) The coil is bolted directly to the cylinder head (Fig. 24). One electrical connector (located at rear of coil) is used for all three coils.

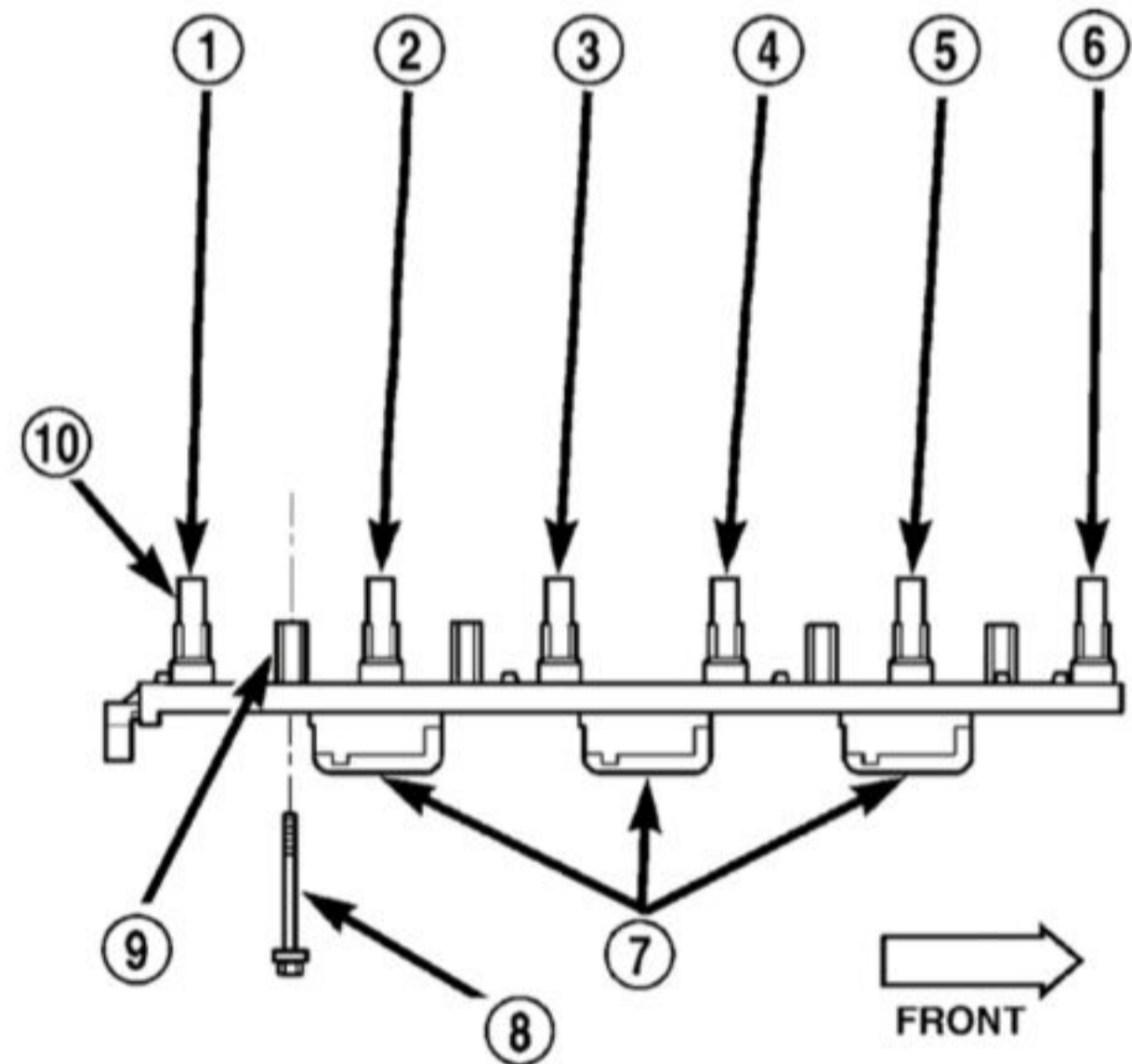

80be45c1

**Fig. 23 Ignition Coil Assembly—4.0L 6-Cylinder Engine**

- 1 - CYL. #6
- 2 - CYL. #5
- 3 - CYL. #4
- 4 - CYL. #3
- 5 - CYL. #2
- 6 - CYL. #1
- 7 - COILS (3)
- 8 - MOUNTING BOLTS (4)
- 9 - BOLT BASES (4)
- 10 - RUBBER BOOTS (6)

**OPERATION - 4.0L**

Although cylinder firing order is the same as 4.0L Jeep engines of previous years, spark plug firing is not. The 3 coils dual-fire the spark plugs on cylinders 1-6, 2-5 and/or 3-4. When one cylinder is being fired (on compression stroke), the spark to the opposite cylinder is being wasted (on exhaust stroke).

**CAMSHAFT POSITION SENSOR - 4.0L (Continued)**

**REMOVAL - 4.0L**

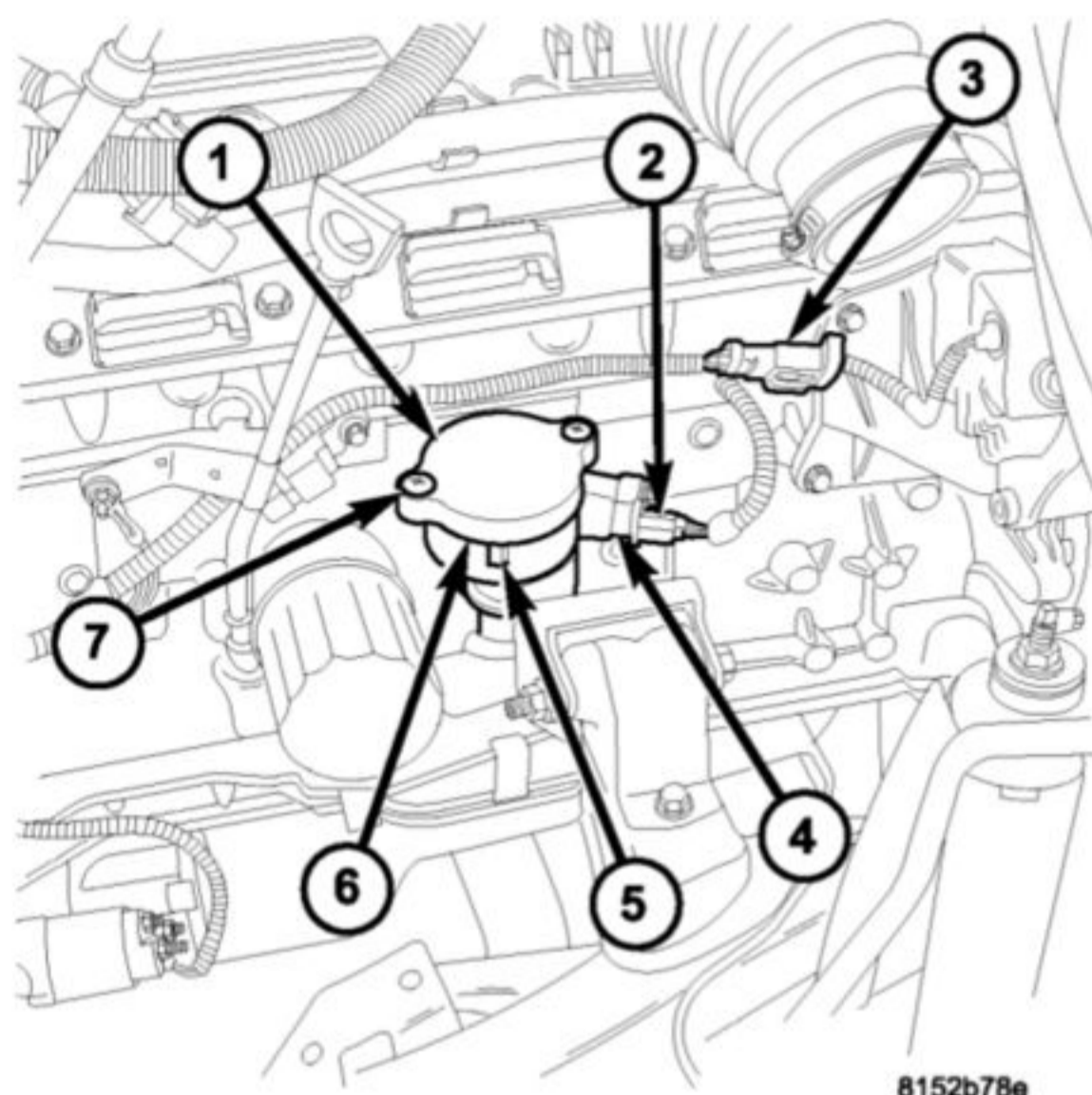

**Fig. 13 4.0L CMP LOCATION ('05)**

- 1 - OIL PUMP DRIVE ASSEMBLY
- 2 - CMP
- 3 - CMP ELECTRICAL CONNECTOR
- 4 - HOUSING HOLD DOWN BOLT
- 5 - HOUSING
- 6 - PLASTIC COVER
- 7 - COVER SCREWS (2)

The Camshaft Position Sensor (CMP) on the 4.0L 6-cylinder engine (2) is bolted to the side of the oil pump drive shaft housing assembly (5) (Fig. 13).

**NOTE: Do not attempt to rotate the oil pump drive assembly to modify ignition timing.**

Two different procedures are used for removal and installation. The first procedure will detail removal and installation of the sensor only. The second procedure will detail removal and installation of the sensor and oil pump drive shaft assembly. The second procedure is to be used if the engine has been disassembled.

**CMP SENSOR ONLY - 4.0L**

- (1) Disconnect CMP electrical jumper harness (3) at engine wiring harness (Fig. 14).
- (2) Remove sensor mounting bolt (3) (Fig. 15).
- (3) Remove sensor (2) from oil pump drive housing (1) (Fig. 15).

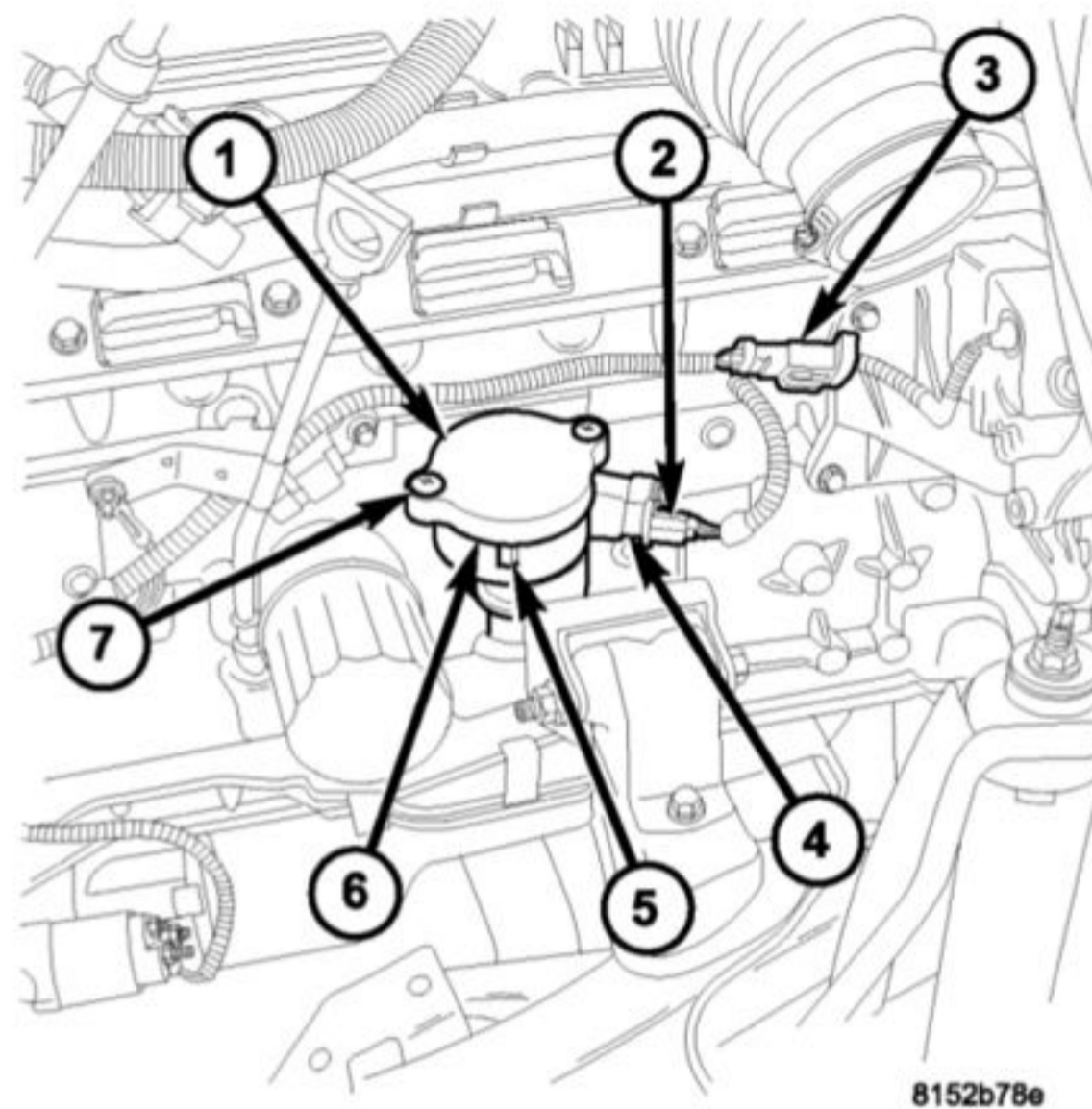

**Fig. 14 4.0L CMP LOCATION ('05)**

- 1 - OIL PUMP DRIVE ASSEMBLY
- 2 - CMP
- 3 - CMP ELECTRICAL CONNECTOR
- 4 - HOUSING HOLD DOWN BOLT
- 5 - HOUSING
- 6 - PLASTIC COVER
- 7 - COVER SCREWS (2)

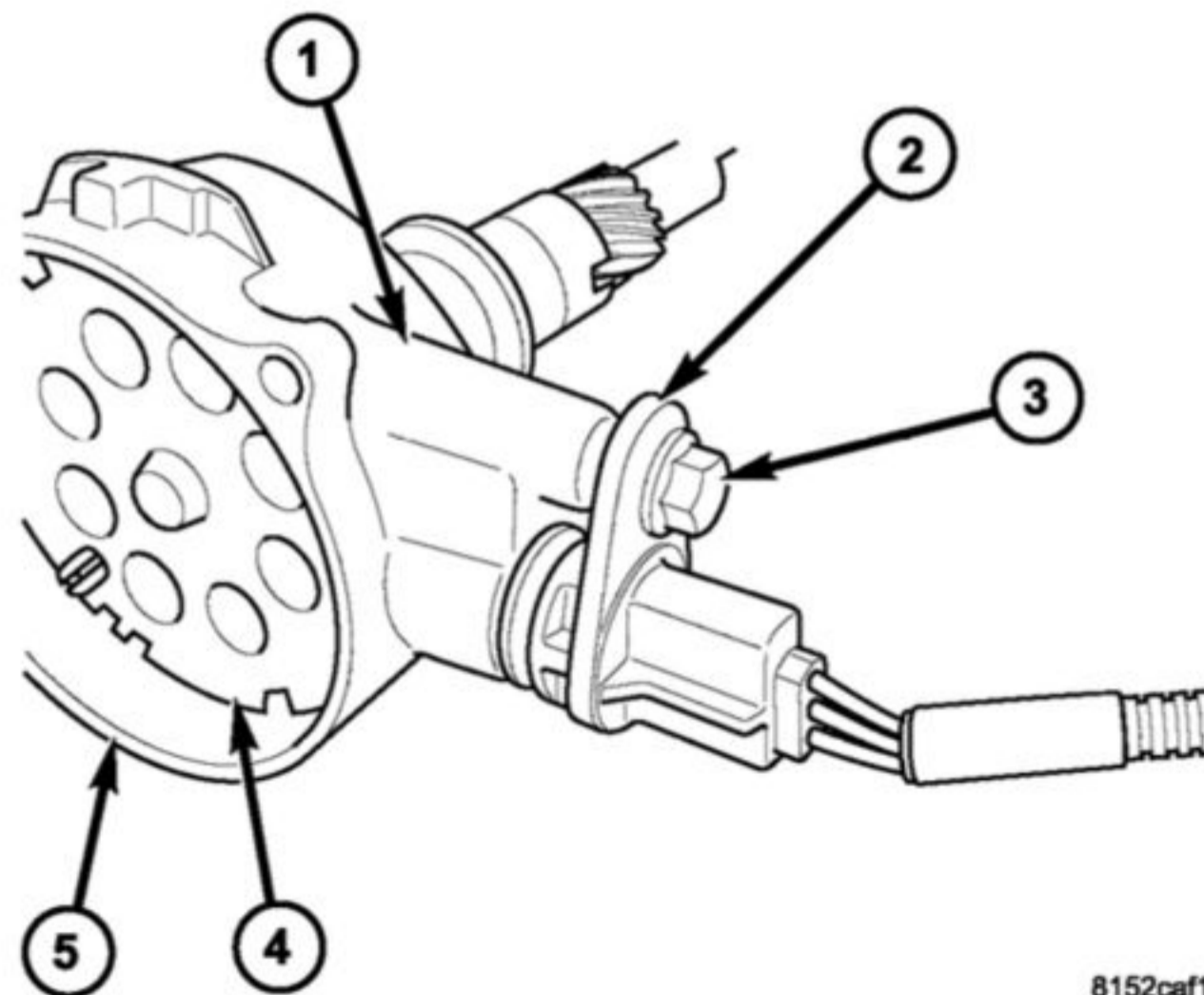

**Fig. 15 4.0L CMP REMOVAL/INSTALLATION**

- 1 - OIL PUMP DRIVE HOUSING
- 2 - CMP SENSOR
- 3 - SENSOR MOUNTING BOLT
- 4 - TARGET WHEEL
- 5 - HOUSING



# WARNING

## California Proposition 65

**Warning:** This product contains chemicals known to the State of California to cause cancer, and birth defects or other reproductive harm.

[www.P65Warnings.ca.gov](http://www.P65Warnings.ca.gov)

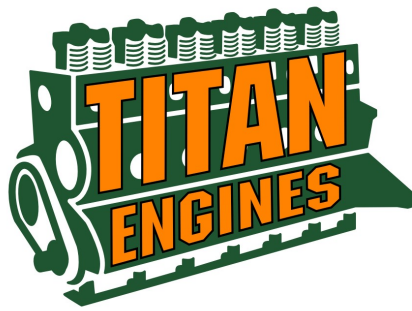

## Warranty

**Titan Engines** offers the following limited warranty on all engines that it sells or manufactures. This is the only warranty provided by Titan Engines. There are no other warranties express or implied, AND NO WARRANTIES OF MERCHANTABILITY OR FITNESS FOR PARTICULAR PURPOSE, which warranties are specifically denied. The only warranties, guaranties, or representations for which TITAN ENGINES is liable are included in this limited warranty unless required by law.

[Are you needing information for the LKQ/ATK Warranty? Click Here](#)

## WARRANTY

TITAN ENGINES will warrant against all defects or failures in manufacturing and internal lubricated parts included in the purchased long block as follows:

- 36 Months and unlimited miles if installed in private passenger cars and light duty trucks.
- 12 Months and Unlimited miles for Pentastar 3.6 engines
- 36 Months and unlimited miles for Chrysler Jeep 3.8 engines
- 12 Months and unlimited miles if installed in commercial vehicles or purchased for marine use.
- 12 Months and unlimited miles if the product is a High performance or Stroker Engine.
- 12 Months for New Cylinder Heads of a Limited Warranty of Parts and Workmanship, Labor Not Included.

TITAN ENGINES will warrant against Parts and Workmanship in purchased Cylinder Heads as follows:

- New Cylinder Heads will come with a 1 Year Limited Warranty of Parts and Workmanship, Labor Not Included. All exclusions of our Standard Warranty still apply.

No Warranties of any nature are provided for Street Strip, Racing series, and short blocks due to the nature of their intended use.

## WARRANTY ACTIVATION

Your warranty is activated from the date of engine shipment. Proof of warranty required will be identification and notation of the engine serial number as well as a valid Invoice number or Sales Receipt number.

## COVERED COMPONENTS

**Covered Components:** The following components are covered in gasoline or diesel engines: pistons, piston pins, piston rings, crankshaft and main bearings, connecting rods and rod bearings,

camshaft bearings, intake and exhaust valves, valve springs, push rods, rocker arms and rocker arm shafts.

- **Block and Heads:** the engine block and cylinder heads are covered only if damaged by Covered Components. Cracks are not covered under this warranty.
- **Seals & Gaskets:** Seals and Gaskets are replaced only incident to repair or replacement of covered components. Leaking gaskets or seals are not covered, repaired, or replaced.
- **Labor:** Labor incurred by TITAN ENGINES only for covered repairs will be paid one time only with the maximum payout of \$400.00
- **Core:** Core returns must be complete to qualify for a core refund. An original invoice number or sales receipt number is required to ensure proper credit. Core return shipping costs incurred by TITAN ENGINES will be deducted from total core value and may impact total refund amount.
- **Replacement parts:** in case of a defect or failure of our engine, our obligation is limited to repairing or replacing damaged, defective, or broken Covered Components as set forth above. It is the sole decision of TITAN ENGINES whether to replace the engine or to replace Covered Components. Replacement of any parts or engine will be completed only once under this Warranty and then it shall be void, and the obligations of TITAN ENGINES shall be deemed fully satisfied.

#### **PROCEDURE:**

If you have a defect or failure with your engine within the prescribed period, contact TITAN ENGINES with an explanation of the problem(s) you are having. Troubleshooting will be attempted by phone or E-mail to identify if the issue is a covered component failure. If it is determined to potentially be a covered component failure, you will be given a return authorization. You will be responsible for having the engine ready for pick up. This means that the engine will be strapped safely to a pallet, and you will provide us with an email address to send you shipping documents. At this time, we will pay the freight for pickup. Upon receipt by TITAN ENGINES the engine will be disassembled and diagnosed. We will determine the reason for the defect or failure. If the defect or failure is related to workmanship or failure of Covered Components that comprise the engine, TITAN ENGINES will repair or replace the engine at its sole discretion. No other parts that are installed in or on or are otherwise a part of your vehicle are covered by this Warranty nor are they the responsibility of TITAN ENGINES.

**Pentastar 3.6 specific requirements** are as follows oil records indicating regular interval oil changes of no more than 3500 miles, correct oil viscosity and type 5w30 Full Synthetic for a GEN1 or 0w20 for GEN2. Engine must have NO indications of overheating. Engine must be installed with new spark plugs and ignition wires. It is highly recommended to disable vehicles Start Stop function to spare the bearings unnecessary wear. Failure to provide proof of these conditions being met could result in a warranty claim denial.

- **Repairs or replacements do not extend or renew this Warranty.**

**EXCLUSIONS:**

The Following problems, events, and conditions are excluded from, and will NOT be covered by this warranty and are NOT the responsibility of TITAN ENGINES nor shall TITAN ENGINES have any obligation to provide payment, refunds, or other compensation for defects or failures caused in whole or in part by these exclusions:

- **Defects or failures caused by overheating (heat tab bulging or melting). Overheating of any kind will void the engine warranty.**
- **Defects or failures caused by lack of lubrication (running out of oil and coolant).**
- **Camshaft lobe or lifter wear on flat tappet lifters.**
- **Detonation of a piston – burned pistons or holes in pistons.**
- **Defects or failures caused by dirt found in assembly.**
- **Damaged or leaking gaskets, seals, or fittings. Two piece, rear main seal leaks are not covered by warranty.**
- **Defects or failures caused by lack of proper break-in procedures and break-in oil for Flat Tappet engines.**
- **Defects or failures caused by storage of engine – Nonuse.**
- **Any field labor or expenses. This mean we do not pay labor, parts, or costs for your engine to be repaired, worked on, evaluated, or reviewed at another facility.**
- **Towing, vehicle rental, oil, oil filter, loss of use, loss of time, lost wages, personal damaged, per diem expenses, storage fees, medical expenses, telephone or rental charges, installation or removal of engine, parts purchased from other vendors, damage to the vehicle or any of its component parts, or any other incidental or consequential damages.**
- **Defects or failures caused by over-revving, accident, abuse, or an operation for which It was not designed.**
- **Defects or failures caused by alteration of either the drive train or the suspension from the original manufacturers' specifications. I.e. unsupported or non-factory gearing or transmissions.**

- **Defects or failures caused by dirty or improper installation. Covers must be thoroughly cleaned before installation.**
- **Overheating or freeze cracks to the block or heads.**
- **Defects or failures caused by failure to maintain proper coolant, fluid or lubrication levels or contaminated fluids, coolants, or lubricants.**
- **Defects or failures caused by fire, flood, vandalism, theft, collision, riots, acts of war, or acts of God, acts of anger, or dropping the assembly from hoists stands and so on.**
- **Defects or failures caused by rust or corrosion.**
- **Defects or failures caused by competition or racing, usages not approved by the vehicle manufacturer, improper load capacity, or improper towing, misuse, or road conditions.**
- **Heat Tabs or Serial Plate being removed.**
- **Excessive oil consumption and diminished performance. PCV system must be well maintained.**
- **Vehicle components that require normal manufacturer's recommended replacement intervals are not covered.**
- **Cracked heads.**
- **Labor charges, in excess of \$400.00**
- **Engine codes unrelated to mechanical failures**
- **Timing errors related to VVT oil control solenoids**
- **Valve damage related to oil control solenoid failure**

If the defect or failure is the result of any issue listed under Exclusions this Warranty is invalid and TITAN ENGINES is free from any claims, demands, judgements, costs, fees, or expenses incurred by you that are in any way associated with or caused by or excluded from coverage by the Exclusions. In such event, after review of the engine TITAN ENGINES will notify you of its findings and the cost to repair, freight, and labor, all of which will be your responsibility. If you decline the offer to have TITAN ENGINES repair or rebuild the engine or otherwise refuse to pay the costs associated with such repair or rebuilding, then all parts will be returned to you and the obligations of TITAN ENGINES under this Warranty shall be deemed fully satisfied.

**TRANSFER:**

The Transfer of this warranty will be allowed only if the TITAN engine is purchased by an automotive business for one Direct sale to a customer of the purchaser, otherwise this warranty is not assignable or transferable to anyone other than the original purchaser.

**TITAN ENGINES' RIGHT TO TERMINATE BENEFITS:**

In the event of a claim, TITAN ENGINES reserves the right to terminate the benefits of this Warranty

upon the discovery of fraud or misrepresentation of a material fact or use of the vehicle in the commission of a crime by the Purchaser or the Purchaser's representative. Evidence of fraud or misrepresentation is forwarded to the proper authorities.

**CLAIM RESOLUTION:**

All claims or disputes relating to this Product Warranty Agreement, or the breach thereof shall be decided by binding arbitration unless we both agree otherwise. Arbitration shall be specifically enforceable under the prevailing arbitration must be filed with us no later than 1 month after the claim or dispute arises. The award rendered by the arbitrator shall be final and judgement may be entered upon it in accordance with applicable law in any court having jurisdiction. The costs of arbitration will be paid equally by each party. Any other costs will be paid by you. If you have any legal claim against TITAN ENGINES, and arbitration is rejected by TITAN ENGINES, you agree that any action, claim or suit shall only be brought in the state courts in Marion County, Florida. If you bring any such action, claim, or suit against us in any court or forum other than in Marion County Florida, we can seek dismissal of you action, Claim, or suit and require that it be maintained in Marion County, Florida.

**NOT INSURANCE:**

This Agreement is a product warranty and is not insurance and is not subject to state insurance laws.

**WAIVER:**

This warranty is the only warranty that is offered by TITAN ENGINES and sets forth the sole obligation of TITAN ENGINES to you or regarding your engine. You hereby waive and relinquish any other rights to pursue any other remedies whether at law or in equity. You agree that this Warranty is your only remedy for any defects or failures. You agree that the purchase of the engine, the mutual promises and covenants contained herein, and the \$10.00 warranty discount provided to you are good and valuable consideration for the limitations set forth in this Warranty. Any and all items left with TITAN ENGINES for more than 60 days without resolution are subject to disposal.